

TIMBER-V

Tag-Isolated Memory Bringing Fine-grained Enclaves to RISC-V

Samuel Weiser* **Mario Werner***
Ferdinand Brassler† **Maja Malenko***
Stefan Mangard* **Ahmad Sadeghi†**
*Graz University of Technology
†TU Darmstadt



Motivation

- Goal: Protect sensitive code and data



Motivation

- Goal: Protect sensitive code and data

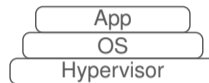

Motivation

- Goal: Protect sensitive code and data

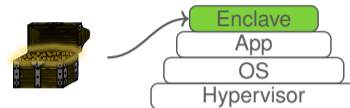

Motivation

- Goal: Protect sensitive code and data from malicious software



Motivation

- Goal: Protect sensitive code and data from malicious software
- Intel SGX is cool, but



Motivation

- Goal: Protect sensitive code and data from malicious software
- Intel SGX is cool, but
 - Closed ISA, microarchitecture
 - Hardware backdoors? [8]

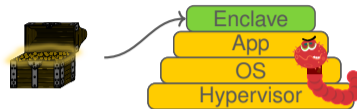

Motivation

- Goal: Protect sensitive code and data from malicious software
- Intel SGX is cool, but
 - Closed ISA, microarchitecture
 - Hardware backdoors? [8]
- RISC-V is completely open

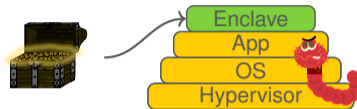

Motivation

- Goal: Protect sensitive code and data from malicious software
- Intel SGX is cool, but
 - Closed ISA, microarchitecture
 - Hardware backdoors? [8]
- RISC-V is completely open
 - **Bring SGX features to embedded RISC-V**

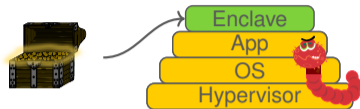

Motivation

- Goal: Protect sensitive code and data from malicious software
- Intel SGX is cool, but
 - Closed ISA, microarchitecture
 - Hardware backdoors? [8]
- RISC-V is completely open
 - **Bring SGX features to embedded RISC-V**
(embedded = ARM Cortex-M)

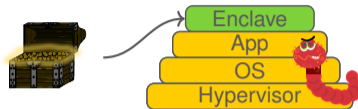

Background: Enclaves

- Secure execution



Enclave

Background: Enclaves

- Secure execution
- Protect against all other software
 - Malicious app

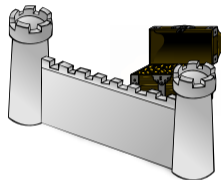

Background: Enclaves

- Secure execution
- Protect against all other software
 - Malicious app
 - Malicious OS

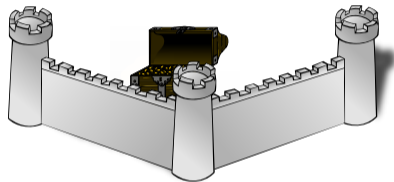

Background: Enclaves

- Secure execution
- Protect against all other software
 - Malicious app
 - Malicious OS
 - Malicious hypervisor

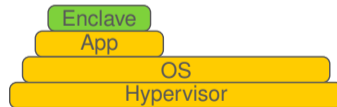
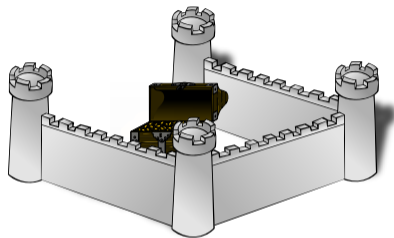

Background: Enclaves

- Secure execution
- Protect against all other software
 - Malicious app
 - Malicious OS
 - Malicious hypervisor
 - Malicious enclaves

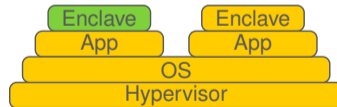
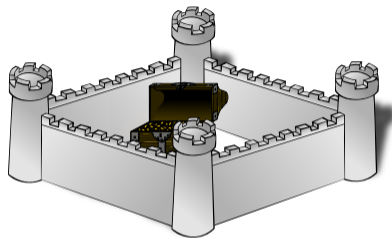

Background: Enclaves

- Secure execution
- Protect against all other software
 - Malicious app
 - Malicious OS
 - Malicious hypervisor
 - Malicious enclaves
- Minimal trust (enclave + HW)

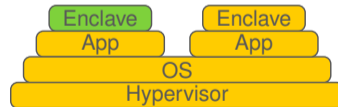
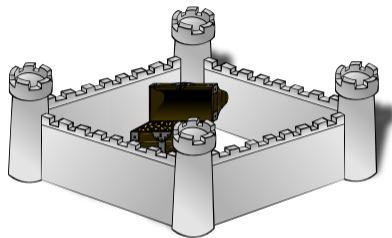

Related Work - Secure Execution

- "Large": Sanctum (RISC-V) [2]
- "Embedded": [3, 4, 7, 1, 9]
 - RISC-V: MultiZone [5], Keystone [6]



Related Work - Secure Execution

- "Large": Sanctum (RISC-V) [2]
- "Embedded": [3, 4, 7, 1, 9]
 - RISC-V: MultiZone [5], Keystone [6]

Problems

- Inflexible isolation boundaries
- **Memory fragmentation**



Problem: Memory Fragmentation

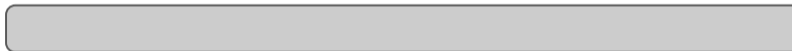

Physical memory

Problem: Memory Fragmentation

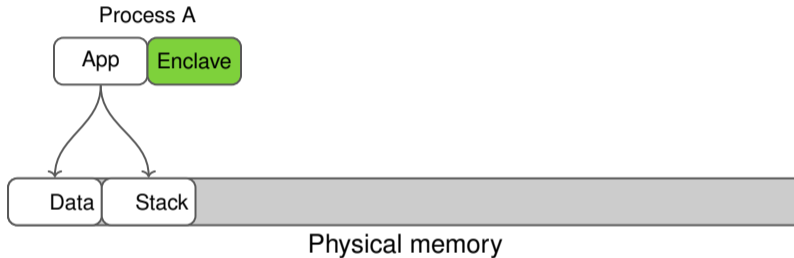

Problem: Memory Fragmentation

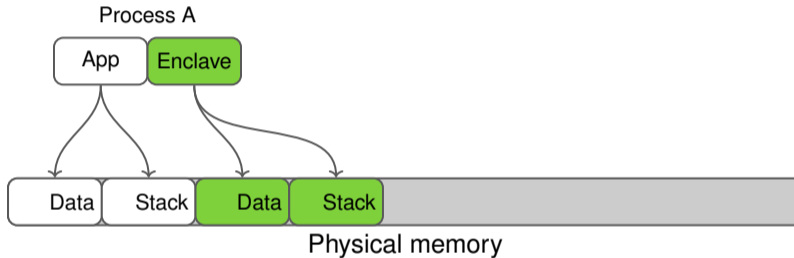

Problem: Memory Fragmentation

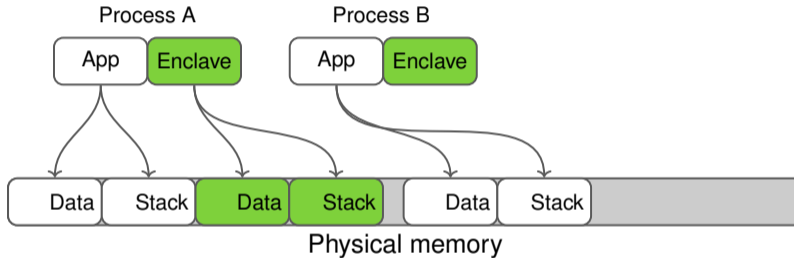

Problem: Memory Fragmentation

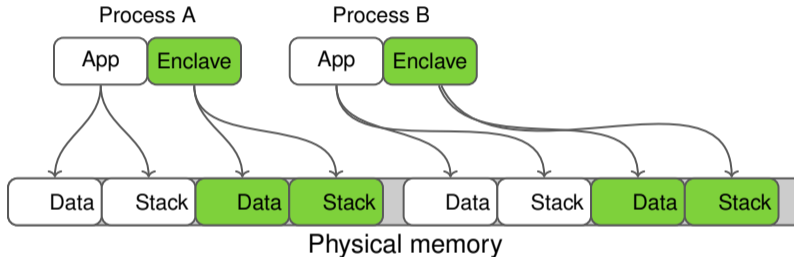

Problem: Memory Fragmentation

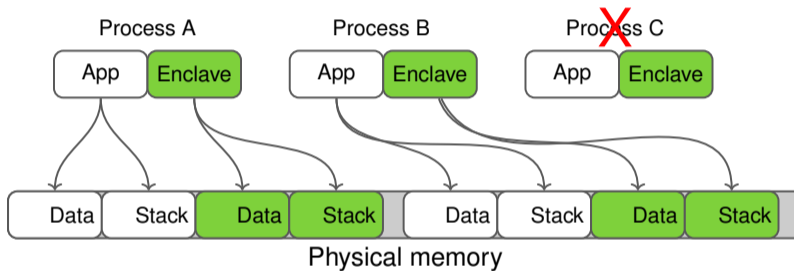

Problem: Memory Fragmentation

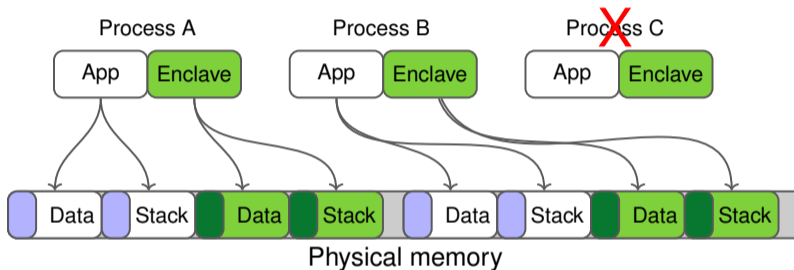

- Bad memory utilization

Problem: Memory Fragmentation

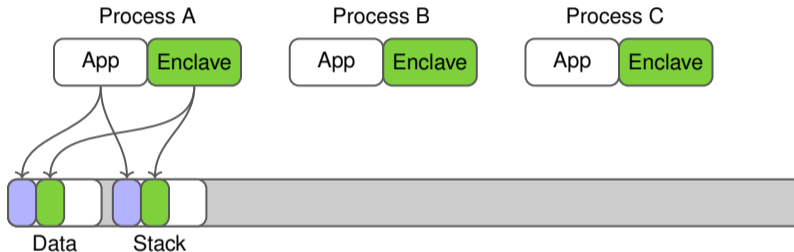

- Bad memory utilization
- We want to interleave memory → Stack sharing

Problem: Memory Fragmentation

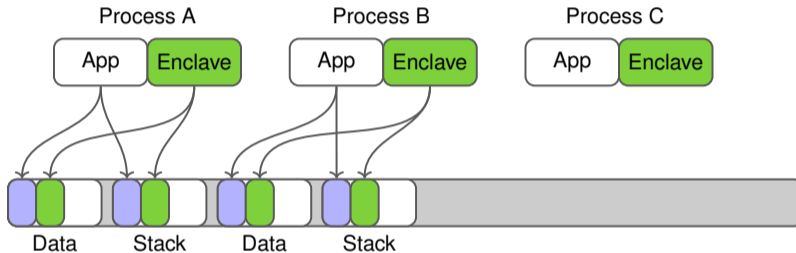

- Bad memory utilization
- We want to interleave memory → Stack sharing

Problem: Memory Fragmentation

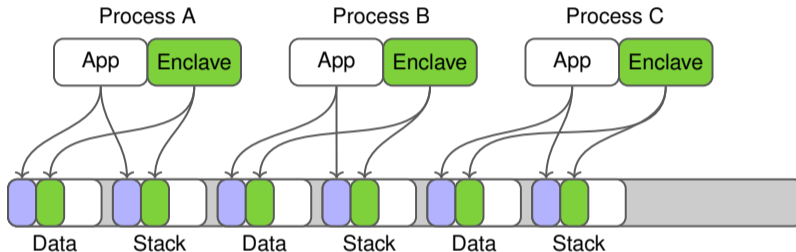

- Bad memory utilization
- We want to interleave memory → Stack sharing

Contributions

- **TIMBER-V**: Enclaves from tagged memory for embedded RISC-V

Contributions

- **TIMBER-V**: Enclaves from tagged memory for embedded RISC-V
- Novel stack sharing

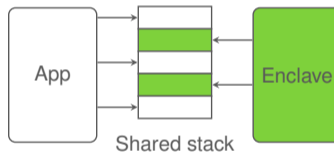

Contributions

- **TIMBER-V**: Enclaves from tagged memory for embedded RISC-V
- Novel stack sharing
- Fast shared enclave memory
- ...
- Proof-of-concept

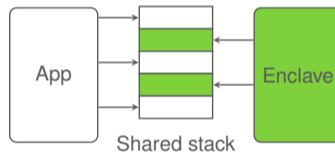

TIMBER-V Overview

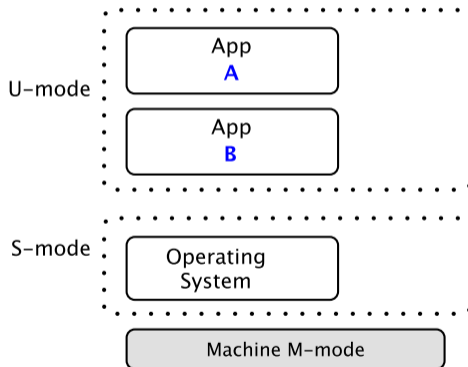

TIMBER-V Overview

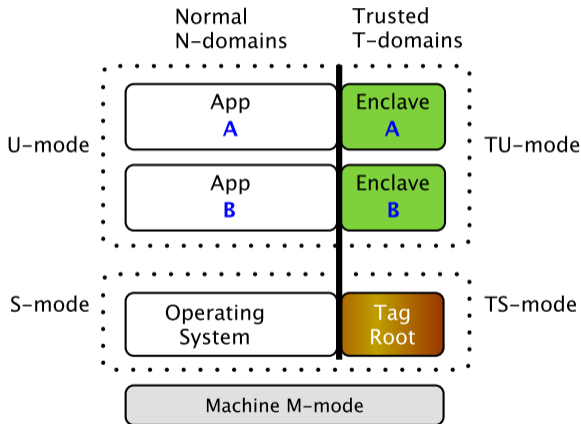

TIMBER-V Overview

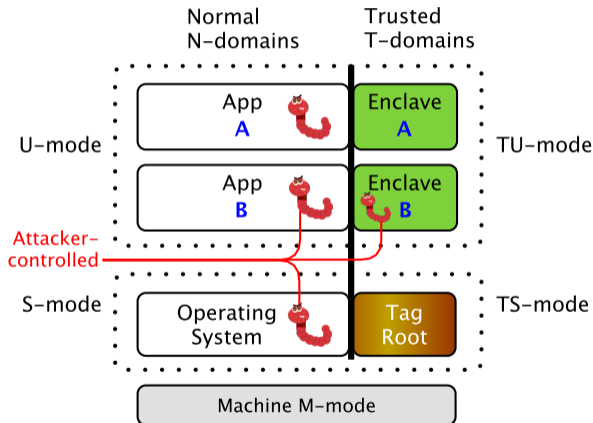

TIMBER-V

Enclave building blocks:



TIMBER-V

Enclave building blocks:

- Memory isolation

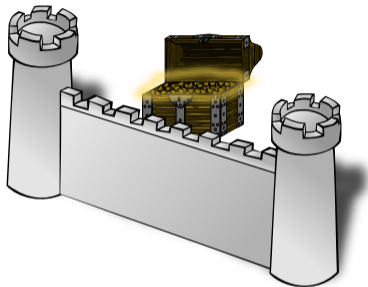

TIMBER-V

Enclave building blocks:

- Memory isolation
- Entry points

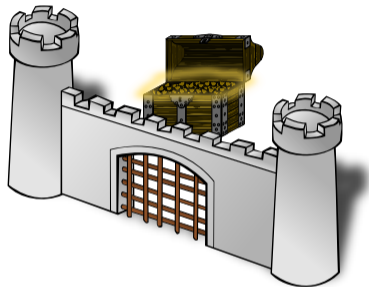

TIMBER-V

Enclave building blocks:

- Memory isolation
- Entry points
- Attestation, sealing
- Inter-enclave communication

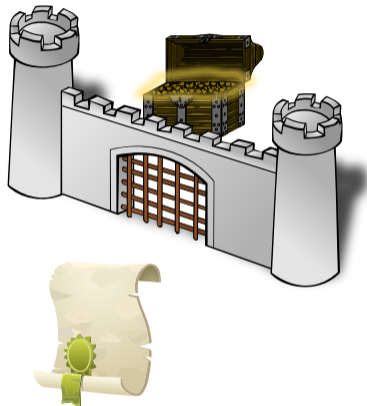

TIMBER-V

Enclave building blocks:

- **Memory isolation**
- Entry points
- Attestation, sealing
- Inter-enclave communication

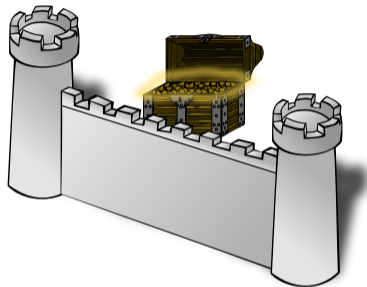

Traditional Memory Protection Unit (MPU)

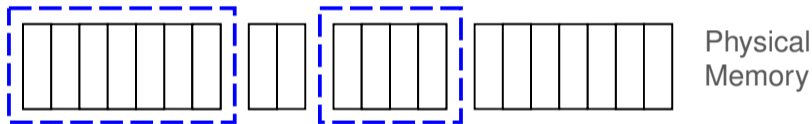

- MPU regions define application
- Problem: inflexible

Tagged Memory



Memory tags →

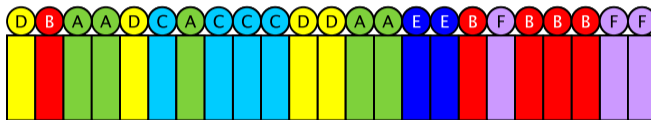

Physical
Memory

Tagged Memory

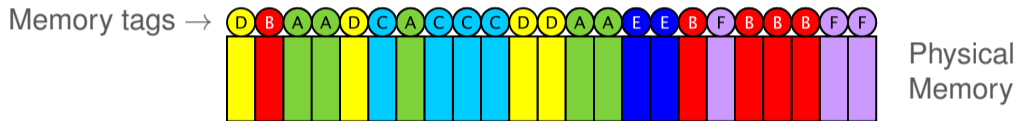

- Memory tags define applications

Tagged Memory

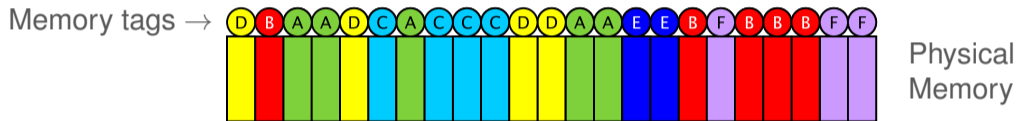

- Memory tags define applications
- Problem: high memory overhead

TIMBER-V: MPU + Tagged Memory

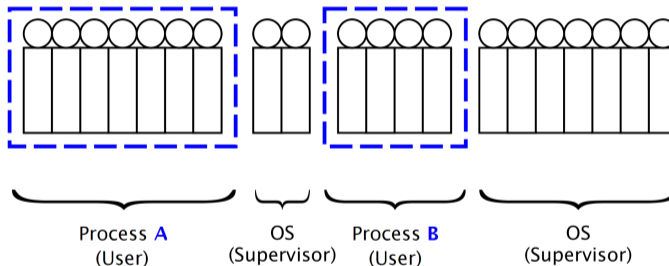

- MPU region defines application

TIMBER-V: MPU + Tagged Memory

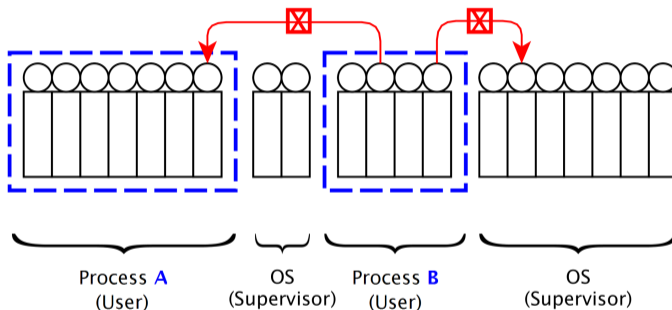

- MPU region defines application
- Application cannot escape

TIMBER-V: MPU + Tagged Memory

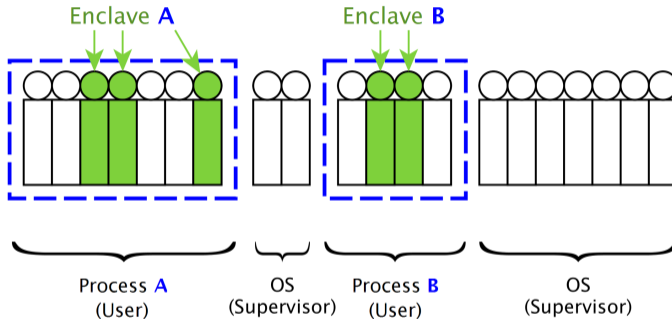

- Memory tag defines enclave

TIMBER-V: MPU + Tagged Memory

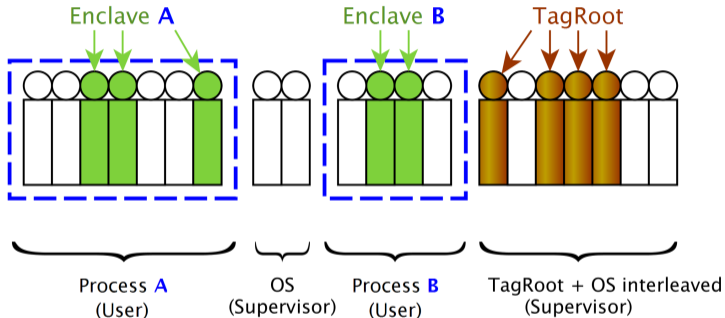

- Memory tag defines enclave
- Memory tag defines TagRoot

TIMBER-V Tag Isolation

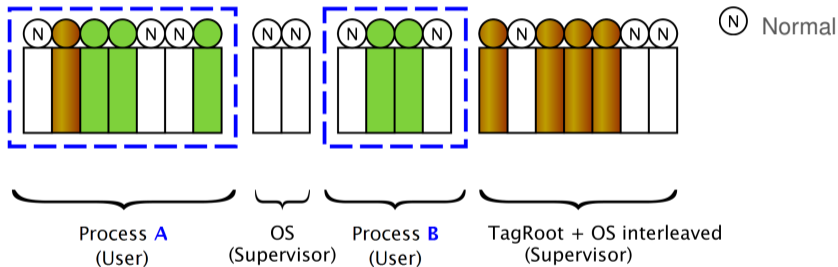

- (N) Normal memory

TIMBER-V Tag Isolation

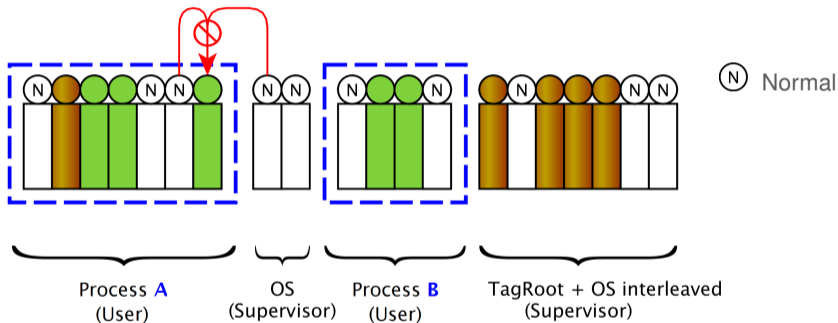

- (N) Normal memory
- Cannot access others

TIMBER-V Tag Isolation

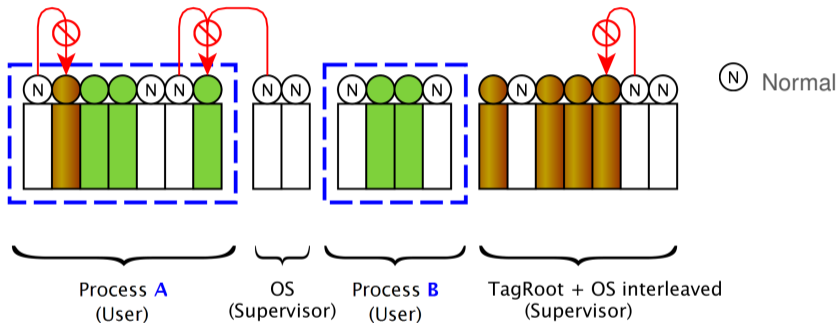

- (N) Normal memory
- Cannot access others

TIMBER-V Tag Isolation

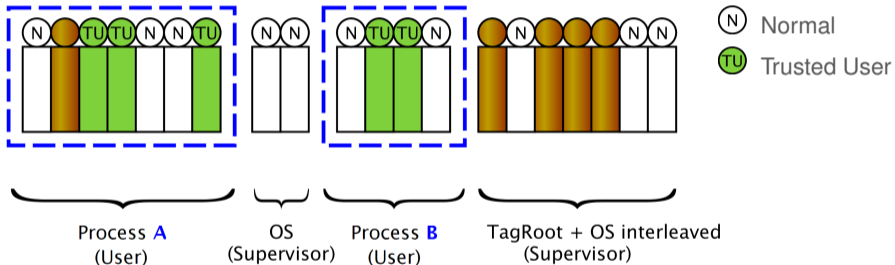

-  Trusted User memory (enclaves)

TIMBER-V Tag Isolation

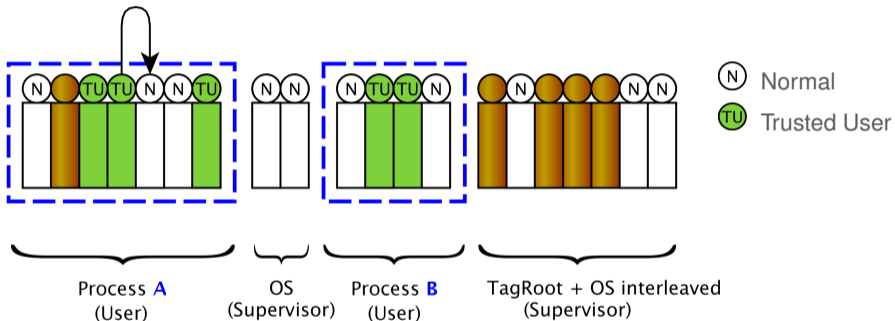

- (TU) Trusted User memory (enclaves)
- Can access and update normal memory

TIMBER-V Tag Isolation

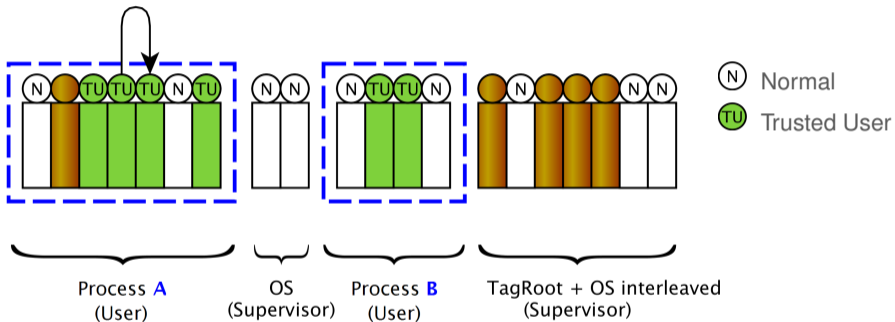

- TU Trusted User memory (enclaves)
- Can access and update normal memory

TIMBER-V Tag Isolation

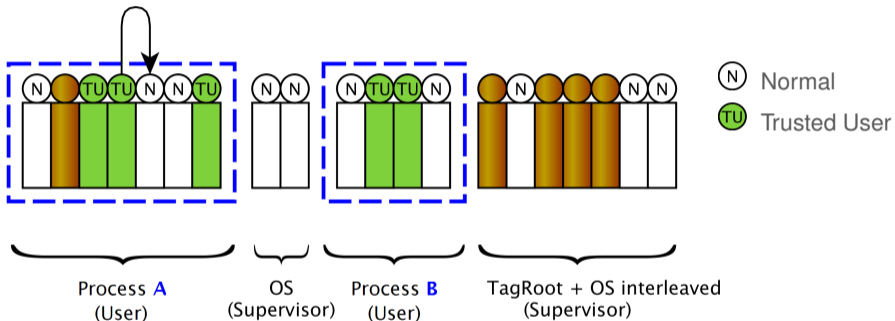

- (TU) Trusted User memory (enclaves)
- Can access and update normal memory

TIMBER-V Tag Isolation

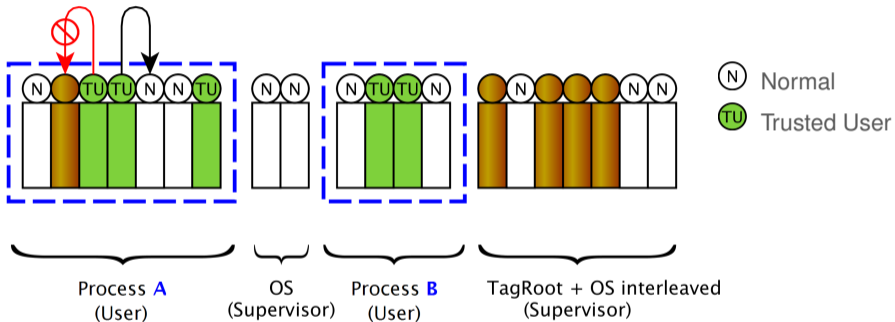

- (TU) Trusted User memory (enclaves)
- Can access and update normal memory

TIMBER-V Tag Isolation

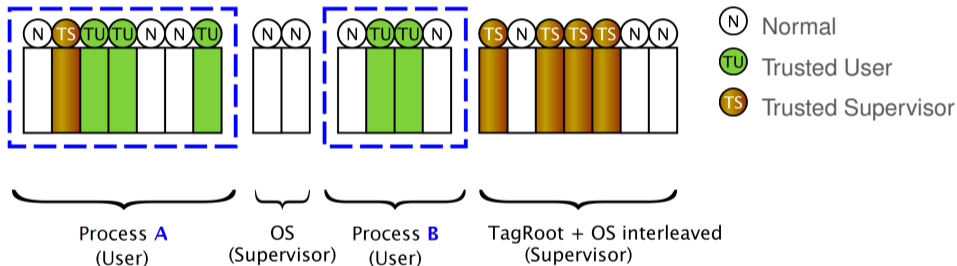

-  Trusted Supervisor memory (TagRoot)

TIMBER-V Tag Isolation

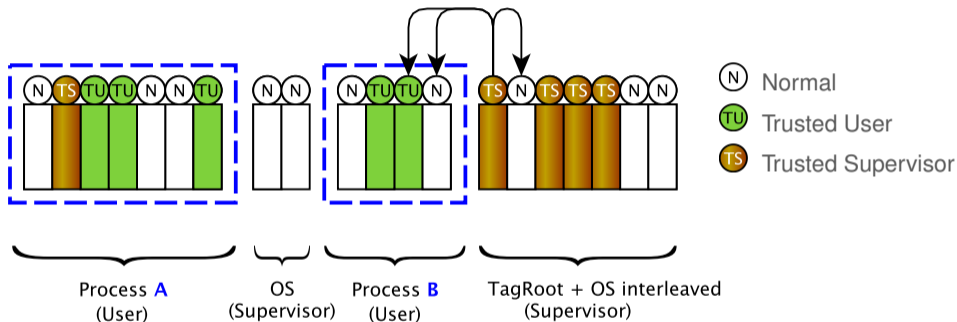

- (TS) Trusted Supervisor memory (TagRoot)
- Can access and update any tag

TIMBER-V Tag Isolation

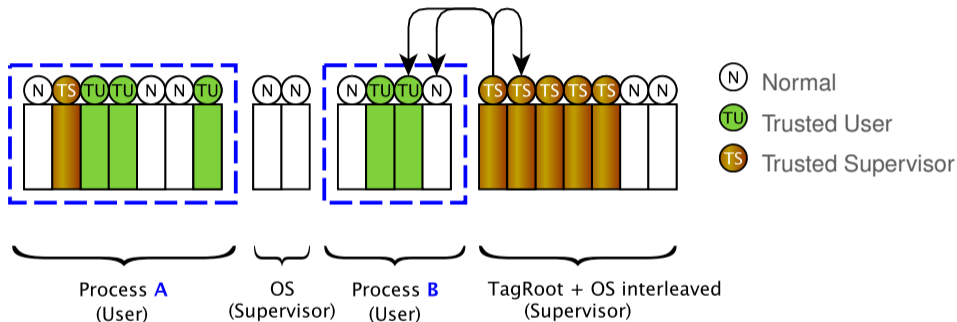

- (TS) Trusted Supervisor memory (TagRoot)
- Can access and update any tag

TIMBER-V Tag Isolation

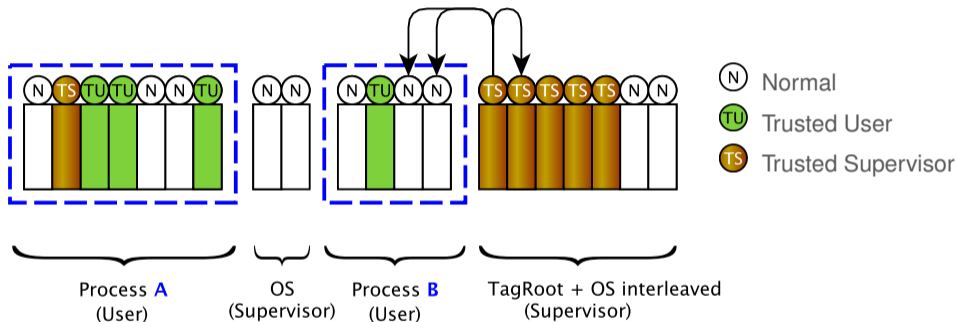

- (TS) Trusted Supervisor memory (TagRoot)
- Can access and update any tag

TIMBER-V Tag Isolation

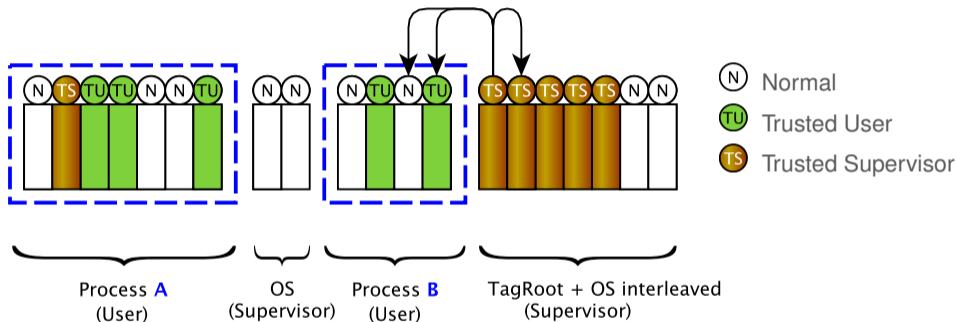

- (TS) Trusted Supervisor memory (TagRoot)
- Can access and update any tag

TIMBER-V Memory Isolation

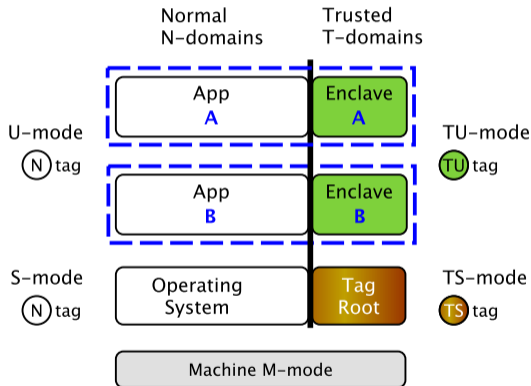

TIMBER-V

Enclave building blocks:

- ✓ Memory isolation
 - Entry points
 - Attestation, sealing
 - Inter-enclave communication

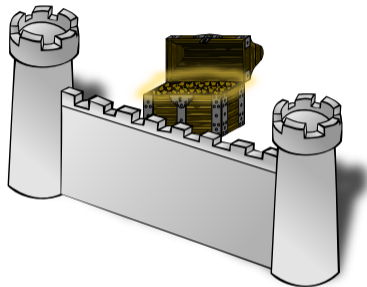

TIMBER-V

Enclave building blocks:

- ✓ Memory isolation
 - **Entry points**
 - Attestation, sealing
 - Inter-enclave communication

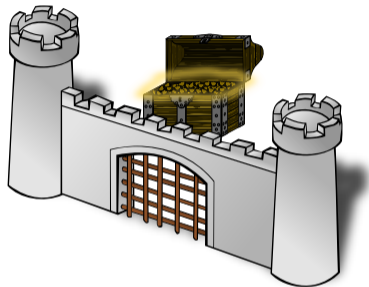

TIMBER-V Entry Points

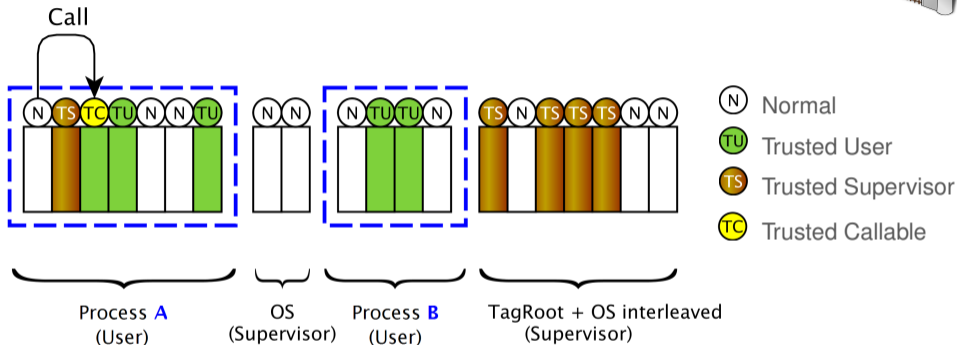

- Enter only at (TC) Trusted Callable

TIMBER-V Entry Points

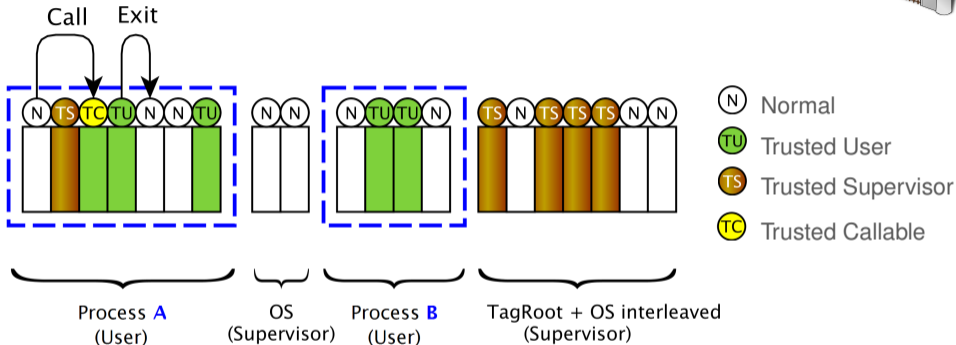

- Enter only at (TC) Trusted Callable
- Zero runtime overhead (ordinary `jmp`)

TIMBER-V Entry Points

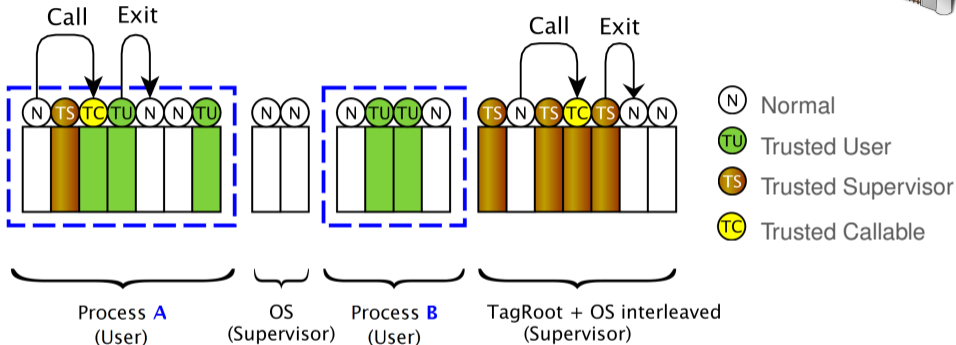

- Enter only at (TC) Trusted Callable
- Zero runtime overhead (ordinary `jmp`)

TIMBER-V Entry Points

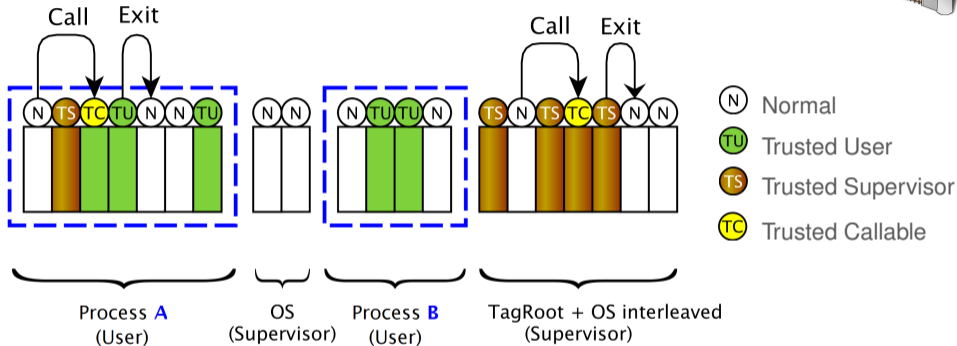

- Four tags → two tag bits only

TIMBER-V Entry Points

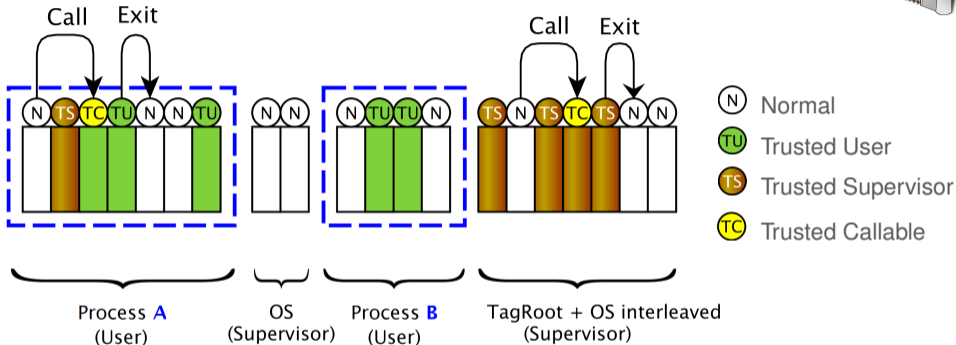

- Four tags → two tag bits only
- For 32-bit system +6.25% memory overhead

TIMBER-V

Enclave building blocks:

- ✓ Memory isolation
- ✓ Entry points
 - Attestation, sealing
 - Inter-enclave communication

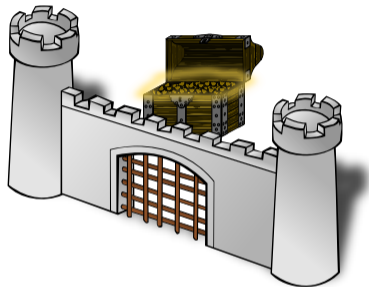

TIMBER-V

Enclave building blocks:

- ✓ Memory isolation
- ✓ Entry points
 - **Attestation, sealing**
 - **Inter-enclave communication**

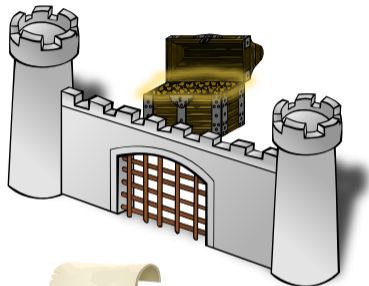

TIMBER-V TagRoot



- Root of trust in privileged software

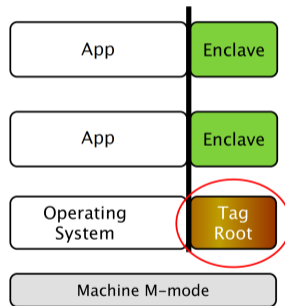

TIMBER-V TagRoot



- Root of trust in privileged software
- Supports SGX and TrustZone model

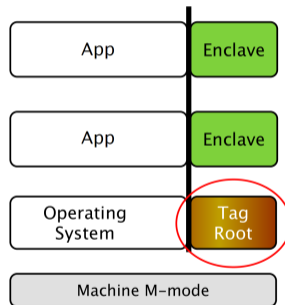

TIMBER-V TagRoot



- Root of trust in privileged software
- Supports SGX and TrustZone model
- Enclave management

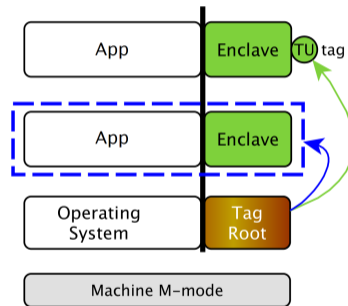

TIMBER-V TagRoot



- Root of trust in privileged software
- Supports SGX and TrustZone model
- Enclave management
- Inter-enclave communication
 - Fast shared memory
 - Mutual authentication
 - Implicit local attestation

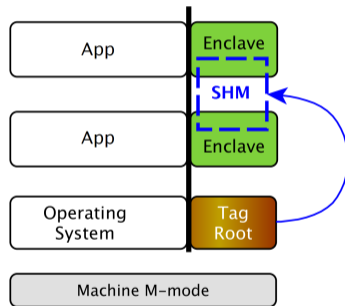

TIMBER-V TagRoot



- Root of trust in privileged software
- Supports SGX and TrustZone model
- Enclave management
- Inter-enclave communication
 - Fast shared memory
 - Mutual authentication
 - Implicit local attestation
- Sealing (like SGX)

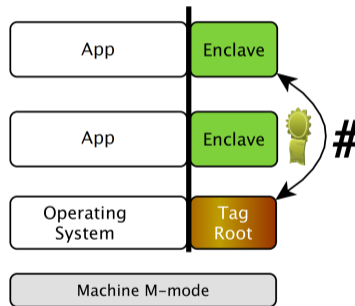

TIMBER-V

Enclave building blocks:

- ✓ Memory isolation
- ✓ Entry points
- ✓ Attestation, sealing
- ✓ Inter-enclave communication

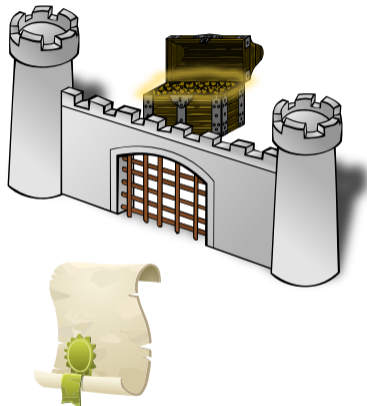

Novel Stack Sharing

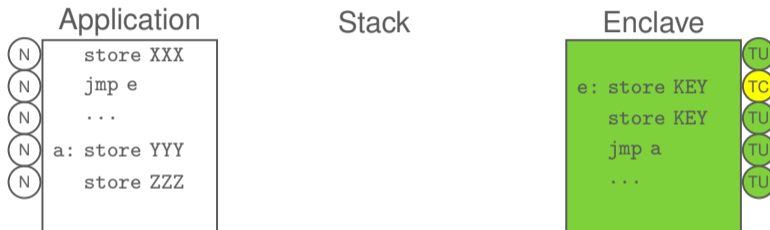

- Single stack shared between application and enclave ...

Novel Stack Sharing

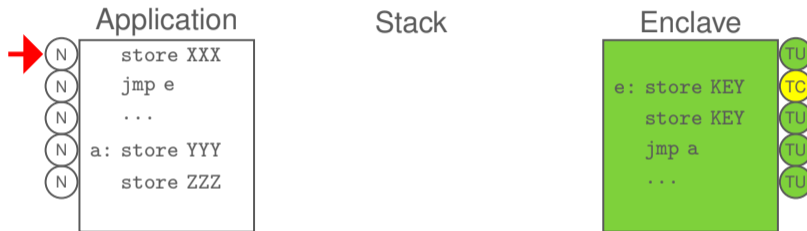

- Single stack shared between application and enclave ...

Novel Stack Sharing

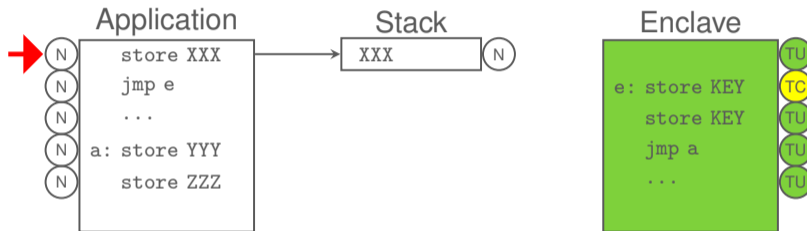

- Single stack shared between application and enclave ...

Novel Stack Sharing

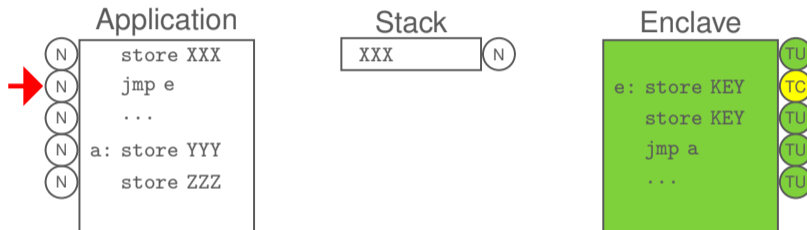

- Single stack shared between application and enclave ...

Novel Stack Sharing

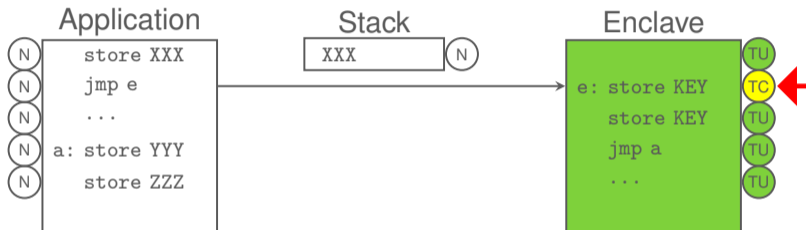

- Single stack shared between application and enclave ...

Novel Stack Sharing

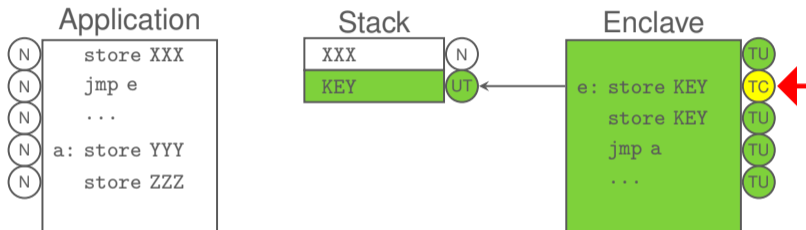

- Single stack shared between application and enclave ...

Novel Stack Sharing

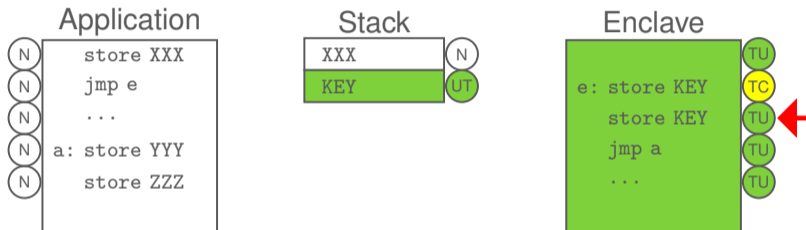

- Single stack shared between application and enclave ...

Novel Stack Sharing

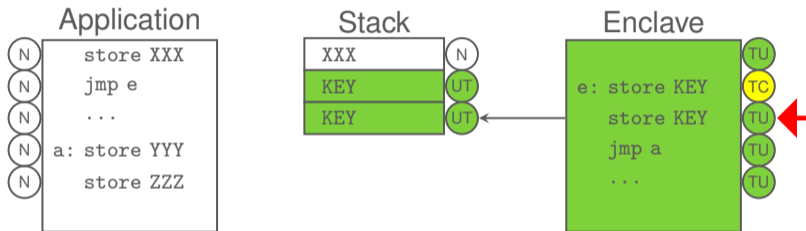

- Single stack shared between application and enclave ...

Novel Stack Sharing

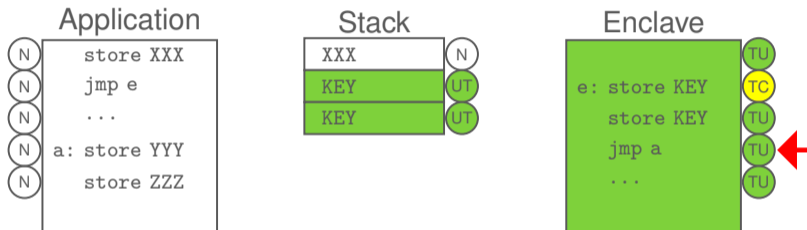

- Single stack shared between application and enclave ...

Novel Stack Sharing

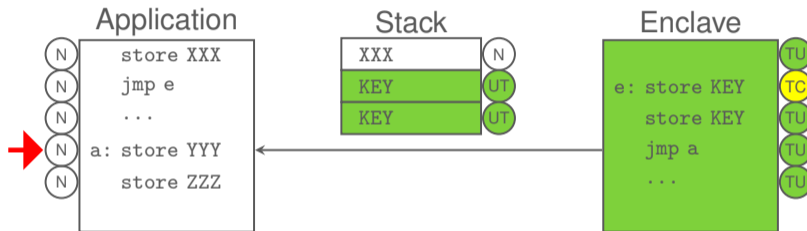

- Single stack shared between application and enclave ...

Novel Stack Sharing

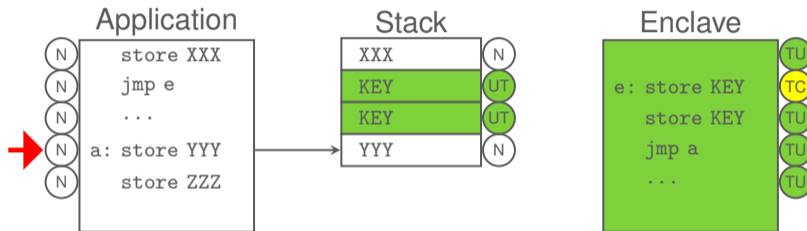

- Single stack shared between application and enclave ...

Novel Stack Sharing

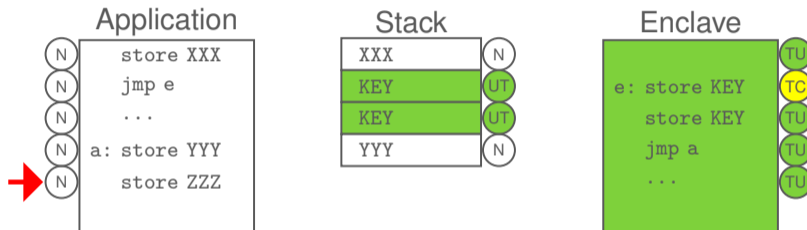

- Single stack shared between application and enclave ...

Novel Stack Sharing

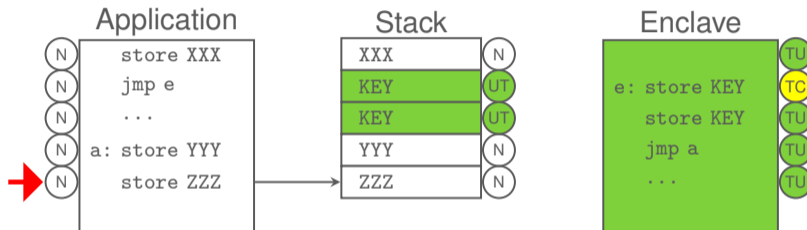

- Single stack shared between application and enclave ...

Novel Stack Sharing

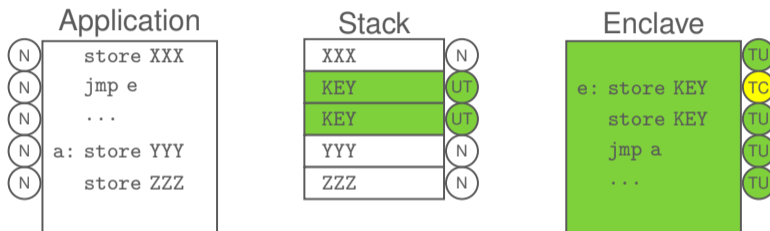

- Single stack shared between application and enclave ...
... and between TagRoot!

Novel Stack Sharing

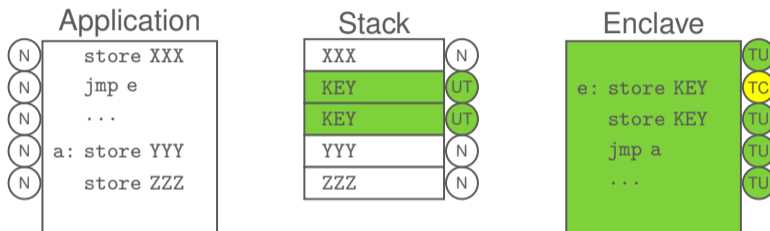

- Single stack shared between application and enclave ...
... and between TagRoot!
- Heap sharing quite similar

Key Insights

- Build enclaves with tagged memory
 - Fine granularity and high flexibility
- Combination with MPU allows tiny 2-bit tags
- Reduced memory fragmentation
 - Shared stacks, heaps ...



Proof-of-Concept

- Integration in ISA simulator (Spike)
- Full TagRoot implementation
- FreeRTOS integration
- Gnu GCC support
- Benchmarks (Coremark, Beebs)
- Open source: github.com/IAIK/timber-v



TIMBER-V

Tag-Isolated **Memory** Bringing Fine-grained Enclaves to **RISC-V**

Samuel Weiser* **Mario Werner***
Ferdinand Brassler† **Maja Malenko***
Stefan Mangard* **Ahmad Sadeghi†**
*Graz University of Technology
†TU Darmstadt



Bonus: New Instructions

	RISC-V	TIMBER-V	Arguments
Load	lb, lbu	lbct, lbuct	etag ← check for expected memory tag
	lh, lhu	lhct, lhuct	etag (fault on mismatch)
	lw	lwct	etag
		ltt	etag ← load and test tag w.o. fault
Store	sb	sbct	etag, ntag ← also store new memory tag
	sh	shct	etag, ntag
	sw	swct	etag, ntag

Bonus: TIMBER-V Overhead Estimate

Average overhead: 25.2% vs 2.6% (with caching of tags)

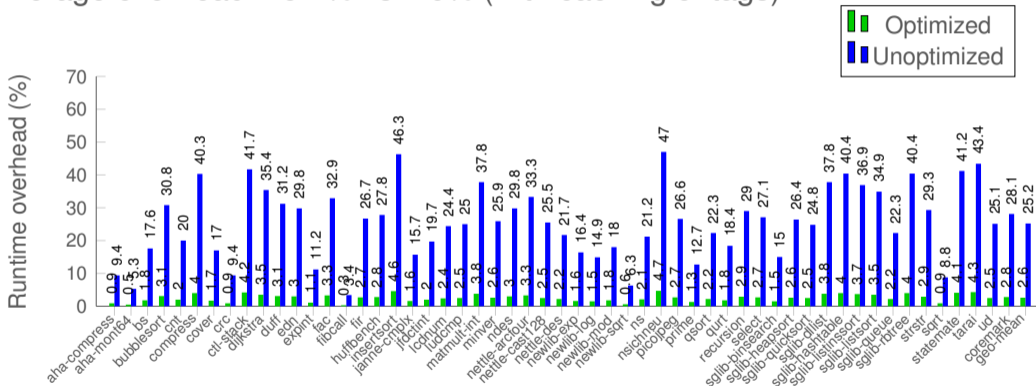

References

- [1] Franz Ferdinand Brasser, Brahim El Mahjoub, Ahmad-Reza Sadeghi, Christian Wachsmann, and Patrick Koeberl. “TyTAN: tiny trust anchor for tiny devices”. In: **Design Automation Conference – DAC’15**. ACM, 2015, 34:1–34:6. ISBN: 978-1-4503-3520-1.
- [2] Victor Costan, Iliia A. Lebedev, and Srinivas Devadas. “Sanctum: Minimal Hardware Extensions for Strong Software Isolation”. In: **USENIX Security’16**. USENIX Association, 2016, pp. 857–874.
- [3] Karim Eldefrawy, Gene Tsudik, Aurélien Francillon, and Daniele Perito. “SMART: Secure and Minimal Architecture for (Establishing Dynamic) Root of Trust”. In: **Network and Distributed System Security Symposium – NDSS’12**. The Internet Society, 2012.
- [4] Johannes Götzfried, Tilo Müller, Ruan de Clercq, Pieter Maene, Felix C. Freiling, and Ingrid Verbauwhede. “Soteria: Offline Software Protection within Low-cost Embedded Devices”. In: **Annual Computer Security Applications Conference – ACSAC’15**. ACM, 2015, pp. 241–250. ISBN: 978-1-4503-3682-6.
- [5] **Hex-Five MultiZone Security - the First Trusted Execution Environment (TEE) For RISC-V**. <https://hex-five.com/products/> (Accessed 2018/12/10). 2018.
- [6] **Keystone: Open-source Secure Hardware Enclave**. <https://keystone-enclave.org/> (Accessed 2018/12/10). 2018.
- [7] Patrick Koeberl, Steffen Schulz, Ahmad-Reza Sadeghi, and Vijay Varadharajan. “TrustLite: a security architecture for tiny embedded devices”. In: **European Conference on Computer Systems – EUROSYS’14**. ACM, 2014, 10:1–10:14. ISBN: 978-1-4503-2704-6.
- [8] Joanna Rutkowska. **Thoughts on Intel’s upcoming Software Guard Extensions (Part 2)**. <http://theinvisiblethings.blogspot.co.at/2013/09/thoughts-on-intels-upcoming-software.html>. (Accessed 2016/10/20). Sept. 2013.
- [9] **TrustZone Technology for ARMv8-M Architecture**. Ref. no. 100690_0200_00_en. https://static.docs.arm.com/100690/0200/armv8m_trustzone_technology_100690_0200.pdf. (Accessed 2018/11/22). 2017.