

Gyrus: A Framework for User-Intent Monitoring of Text-Based Networked Applications

Yeongjin Jang*, Simon P. Chung*,
Bryan D. Payne†, and Wenke Lee*

*Georgia Institute of Technology

† Nebula, Inc

Traditional Host-Based Security

- Misuse detection: cannot handle unknown attacks
- Anomaly detection: mimicry attacks

Motivation

- Defining attack is hard
 - 0-day, mimicry attack, and etc...
 - Attacks are keep evolving...
- Then, can we design a security monitor that works for the new attacks?

A New Approach

- Objective
 - Protecting *integrity* of user intended **text content** that will be sent as **network packets**.
- Attack-agnostic Defense
 - It does **not** depend on the **how** the attack works.
 - Examples of the ways of attacks
 - Attach to a process to change some text values...
 - Directly write on /dev/mem to modify sensitive values...
 - We only make sure the monitored system is behaving **correctly**
 - Essentially looking at the opposite side of attack detection.

Related Works

- Using Timing Information
 - BINDER [ACSAC 05', Cui et. al.]
 - Not-A-Bot, [NSDI 09', Gummadi et. al.]
 - User-intent Detection
 - Monitors physical keystrokes/mouse clicks
 - A traffic without user input preceded in a short time window is not user-intended, a malicious activity.
 - User-intended behavior: $T_{\text{network}} - T_{\text{input}} < T_{\text{threshold}}$
 - Simple, but effective defense for existing attacks

Related Works (Cont'd)

- User-Driven Access Control [Oakland 12', Roesner et. al.]
 - Access Control Gadget (ACG)
 - A UI gadget that grants permission to the resource when it is clicked.
 - Examples
 - » Camera icon -> grant access to camera
 - » File-saving icon -> grant access to filesystem

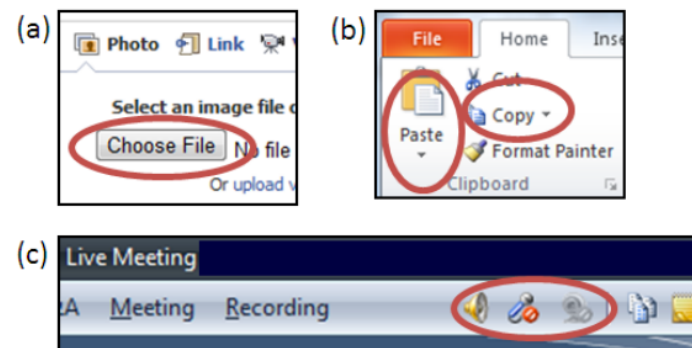
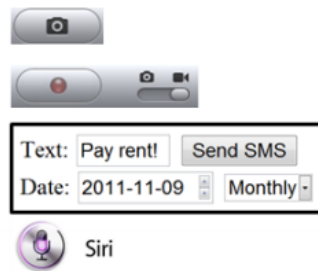

Related Works (Cont'd)

- Problem
 - Only checks existence of user intent (yes/no)
 - BINDER & Not-A-Bot
 - Send malicious network traffic shortly after **every keystrokes**
 - ACG
 - **Free** to use the resource after getting of the access
 - Nobody took account into monitoring user-intended content.
 - Why?

Capturing User-intended Text

- Straightforward way
 - Looking at keystrokes
 - Keycode can be caught at keyboard driver
 - 'w', 'r', 'i', 't', 'e', 'ENTER'
 - Cursor point and button can be caught at mouse driver
 - (x, y, button) -> (325, 641, LCLICK)

Capturing User-intended Text

- A better approach
 - User interacts with computer using input/output hardware
 - Input: Keyboard, Mouse
 - Output: Display screen
 - Feedback loop in the user interaction

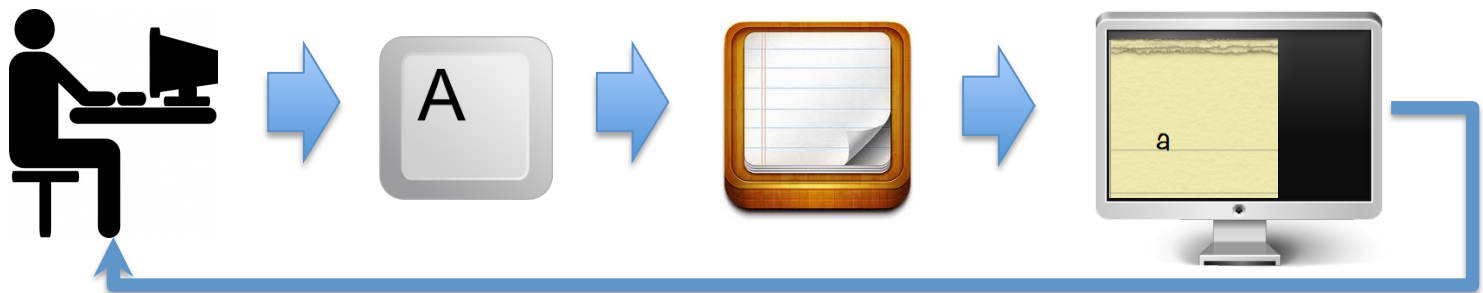

Capturing User-intended Text

- Observation
 - User naturally verifies what they type by what they sees on the screen
- A New Security Policy
 - What You See Is What You Send (WYSIWYS)
 - We assume on-screen text is user-intended
 - Only allows outgoing traffic that matches on-screen text

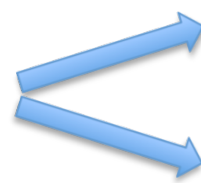

Hi, there!



Hey, send me \$100



Secure Overlay

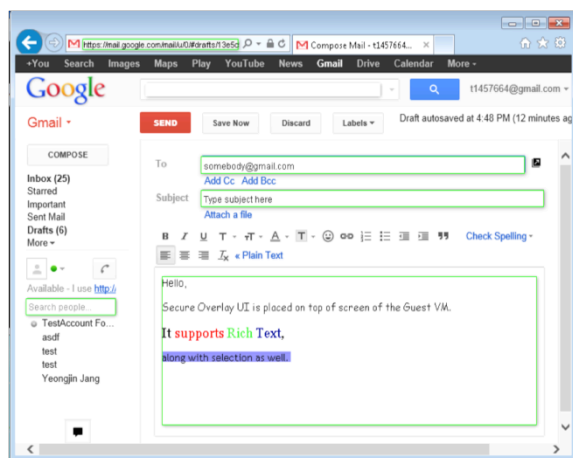

Combined Screen

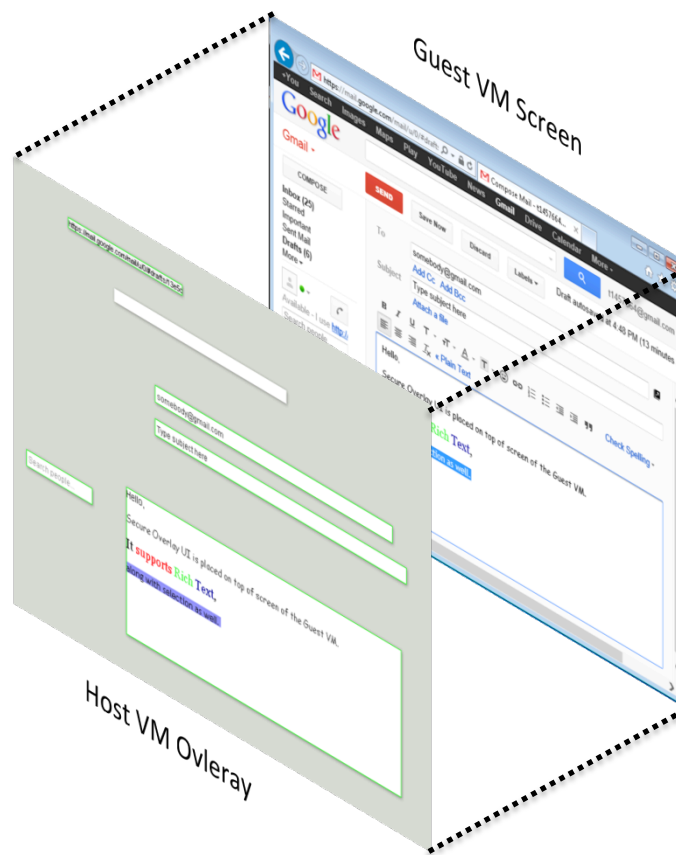

On-screen text is always **same** with captured text on the security monitor.

Secure Overlay

- Only re-draws editbox
 - Exactly same location, size, and color
 - Can support rich-text
 - Font, size, color, style, and etc.
- Passive UI
 - It does not gets any user input.
 - Content will be updated after each applications gets input.
 - Support selection, copy/paste, spell correction, auto-completion, etc...

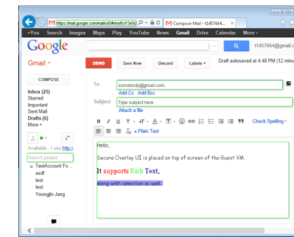

Combined Screen



UI Monitor

- Uses library for UI Testing (UIAutomation)

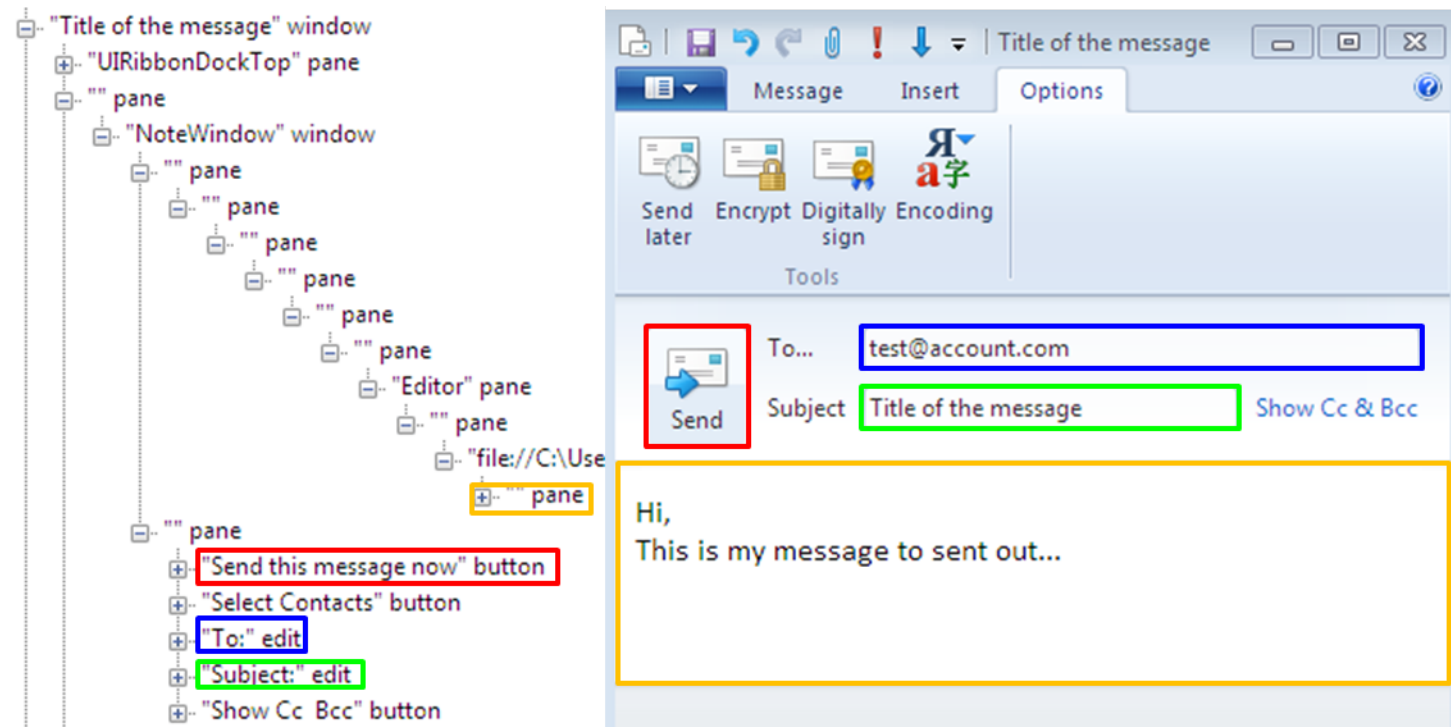

The Gyrus Architecture

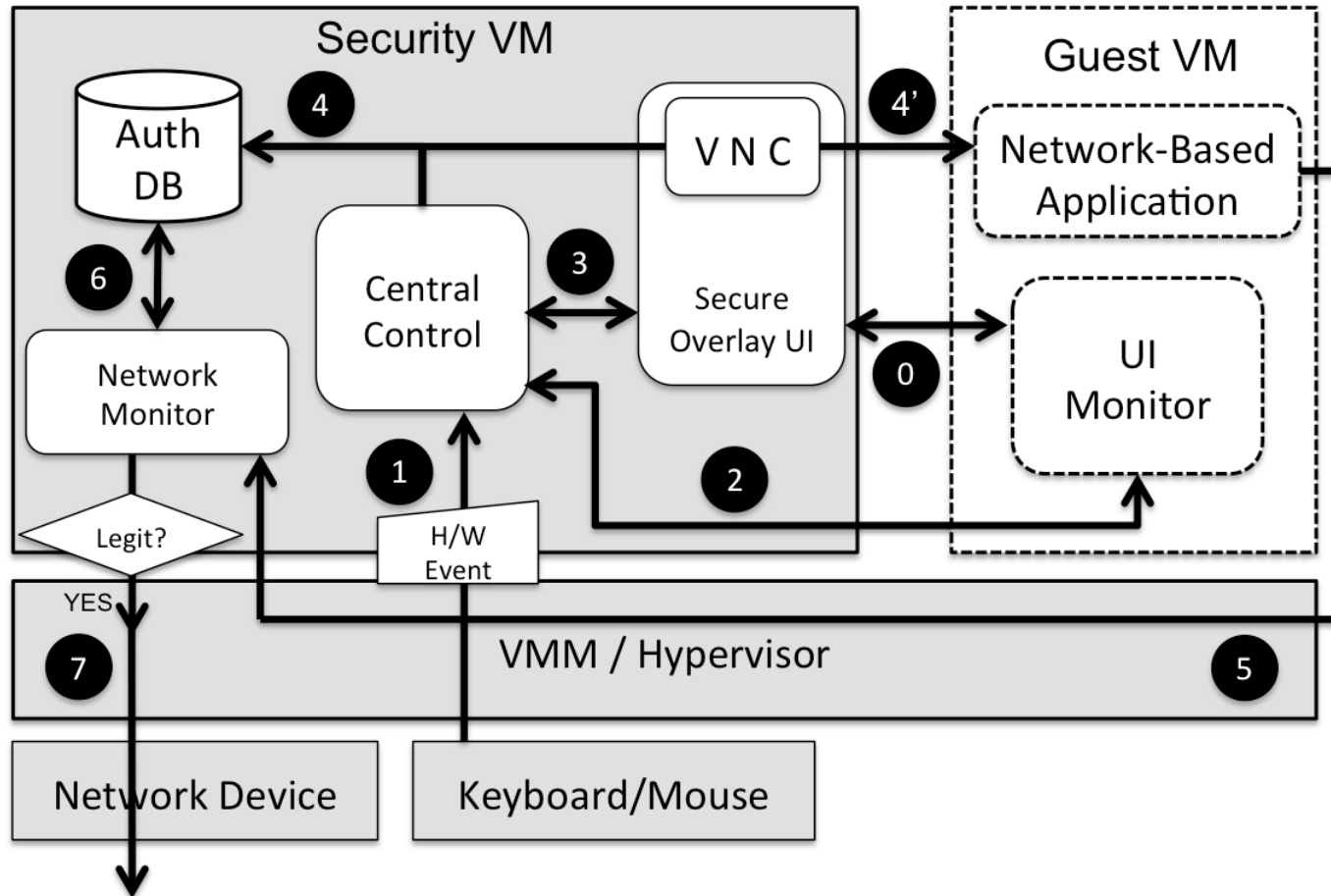

Threat Model

- Hypervisor and security VM is **fully trusted**.
 - Assumes VM escape is impossible.
- Hardware input devices are trusted, and the attacker has **no physical access** to it.
 - Attacker cannot forge hardware input event

Threat Model (Cont'd)

- All hardware input event is interposed at hypervisor first, then delivered to User VM
 - Security VM cannot miss hardware event, and User VM **cannot emulate** it.
- We completely distrust User VM
 - We allows all attacks including **Kernel-level malware**.
 - UI monitor is untrusted.

How Gyrus Works

- Identifying and overlaying all editboxes
 - Only shows for focused window
 - Suppress background update
- Track updates
 - Updates all editbox on
 - Change of focus
 - Change of location
 - Change of content

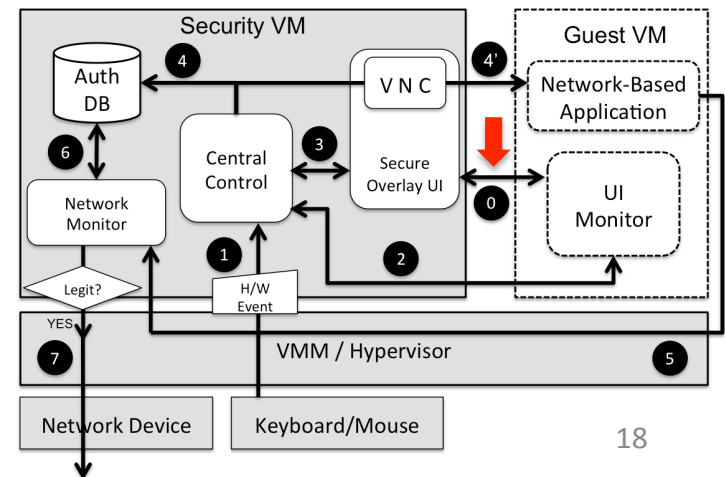
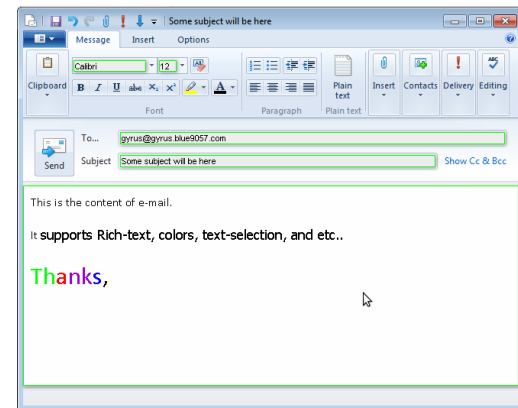

Capture User-Intent

- Extract all required text from Secure Overlay when traffic-triggering event happens.
 - Store it to Authorization DB for enforcement at network level.

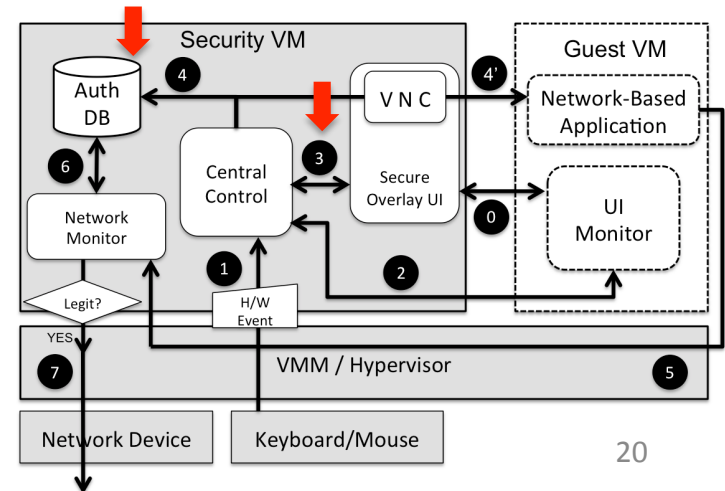
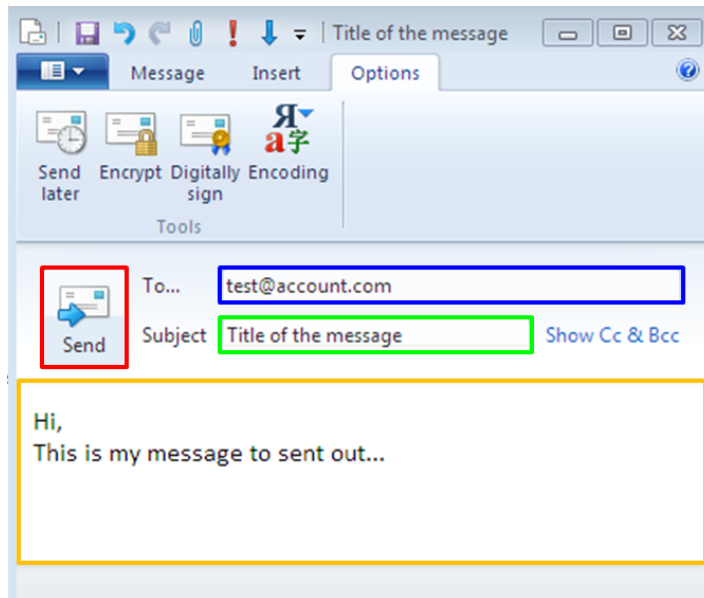

Application-specific Logics

- User Intent Signature

Example 1 User Intent Signature for sending e-mail on Windows Live Mail.

```
{
  "TAG" : "LIVEMAILCOMPOSE",
  "EVENT" : "LCLICK",
  "WINDOW" : "ATH_Note",
  "COND" : {
    "0" : {
      "CONT" : "BUTTON",
      "NAME" : "Send this message now"
    },
    "+2" : {
      "CONT" : "EDIT",
      "NAME" : "To:"
    },
    "+3" : {
      "CONT" : "EDIT",
      "NAME" : "Subject:"
    },
    "P-1CCCCCCCC" : {
      "CONT" : "PANE"
    }
  },
  "CAPTURE" : {
    "A" : "+2.value",
    "B" : "+3.value",
    "C" : "P-1CCCCCCCC.value"
  },
  "TYPE" : "SMTP",
  "BIND" : {
    "METHOD" : "SEND",
    "PARAMS" : {
      "to" : "A",
      "subject" : "B",
      "body" : "C"
    }
  }
}
```

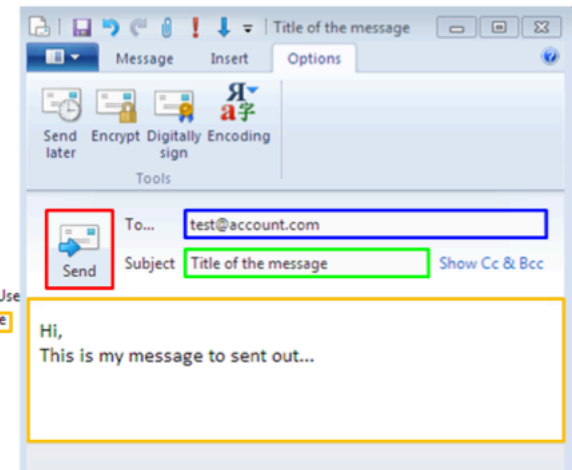
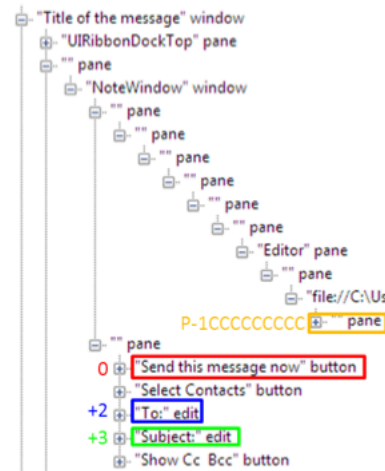

Network Monitor

- A transparent proxy with deep-packet inspection
 - Extract user-intent from the traffic, query authorization DB
 - Pass only when it is matched with stored intent...
- Requires proxy per each protocol
- SSL traffic should be decrypted (MITM)

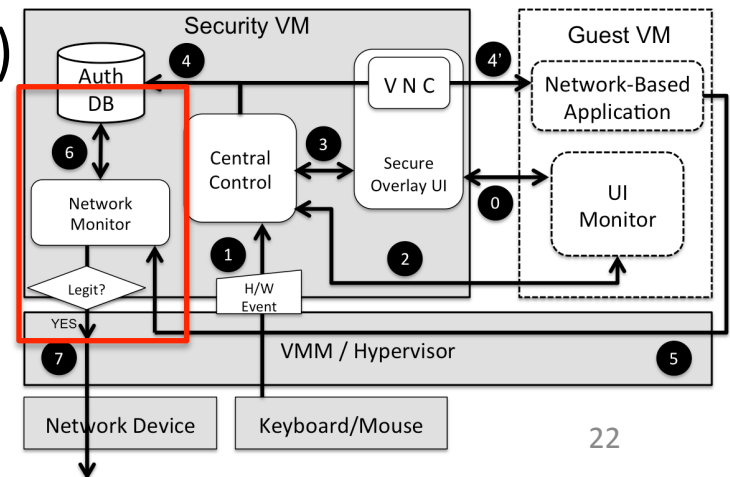

Application Examples

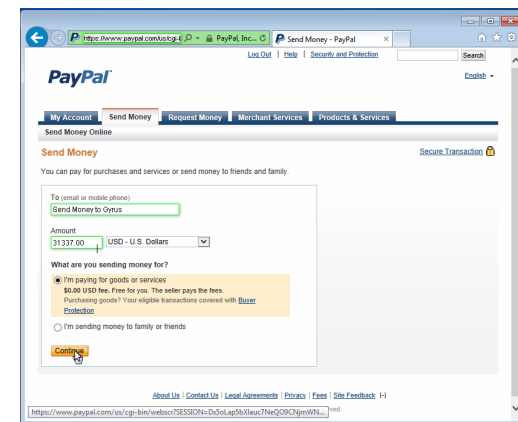
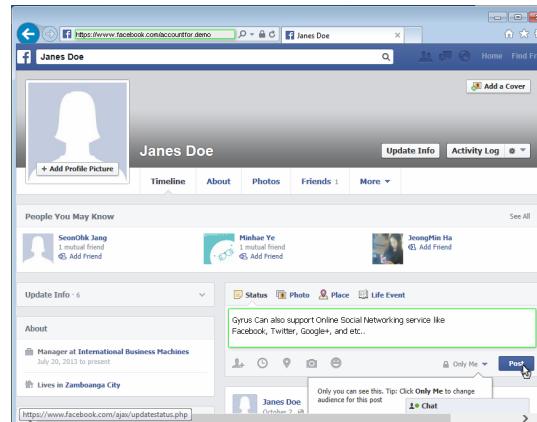
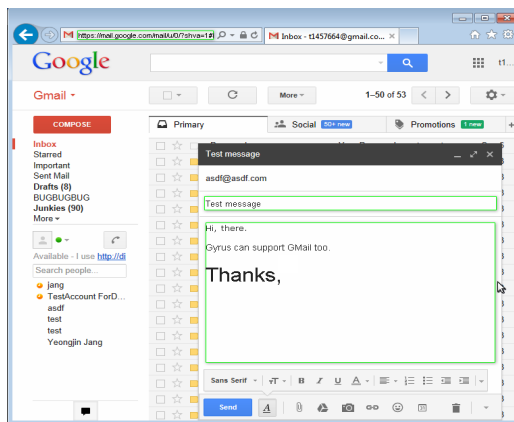
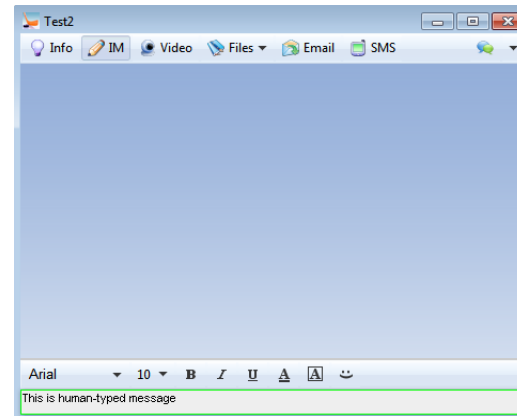
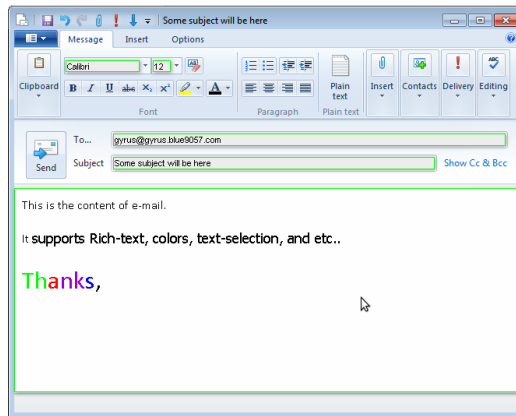

Evaluation

- Security
 - For existing attacks on Apps
 - WYSIWYS is enforced
 - All malware failed to send their traffic on
 - » E-mail client (send spam)
 - » Internet Messenger (send spam)
 - » Facebook (post article, message, and etc.)
 - » Paypal (XSS)
 - » Etc..

Evaluation

- Security
 - Incorrect User Intent Signature
 - On attacking UI monitor in Guest VM
 - Failure on getting correct information
 - False positive, user traffic will be blocked
 - DoS

Evaluation

- Performance

- Interaction delay

- Checked turn-around time starting from the input, end with the resulting text or actions on the Overlay
 - Can handle around 1,400 inputs / min (43ms delay)

Actions	Average	STDV	Median	Max
Typing	39ms	21ms	34ms	128ms
ENTER	19ms	6ms	17ms	43ms
LCLICK	43ms	15ms	41ms	79ms
Focus Change	21ms	19ms	17ms	158ms
Move & Resize	21ms	16ms	16ms	85ms

TABLE II. LATENCY INTRODUCED BY GYRUS WHILE PROCESSING THE INPUT. USER-INTERACTION DATA WAS COLLECTED DURING THE USE CASE EVALUATION.

Evaluation

- Performance
 - Network delay

Cases	KVM	Gyrus	Overhead
Single (A)	101.7ms	102.3ms	+0.6ms (.5%)
Single (B)	31.20ms	32.30ms	+1.1ms (3.5%)
Web Page	897.5ms	951.3ms	+53.8ms (6%)
Download	51.1MB/s	49.3MB/s	-1.8MB/s (3.5%)

TABLE III. NETWORK LATENCY FOR HTTP CONNECTION.

Cases	KVM	Gyrus	Overhead
Single Request	90.72ms	94.50ms	+3.78ms (4%)
Download	37.40MB/s	35.23MB/s	-2.17MB/s (5.8%)

TABLE IV. NETWORK LATENCY FOR HTTPS CONNECTION (WITH MAN-IN-THE-MIDDLE PROXY).

Limitations

- Can only handle text so far.....
 - File/Image attachments
 - What we see: name of path (e.g., c:\boot.ini)
 - What machine sends: content of the file
 - Using ACG would be helpful
- Only works if what you see is really what you send
 - Not the case if displayed text undergone a lot of (proprietary) processing before being sent out.
 - However, base64, SSL, and REST API through HTTPS can be handled.

Conclusion

- Gyrus
 - A correct-behavior based monitoring system.
 - Monitors user-intended text through on-screen UI data, and enforcing WYSIWYS policy.
 - Protect most of text-based user applications with minimal overhead.
 - Its attack-agnostic defense works for preventing future attacks.

Questions?

- Q&A

Discussions

- Attacks on UI monitor
 - Malware that tries to modify text
 - At network monitor, it only allows text in the authorization DB.
 - Authorization DB only stores on-screen text.
 - => The text content malware would send should be on-screen.
 - => User will be notified from on-screen changes.

Future Works

- Implement in different platform
 - Android (Dalvik VM)
 - Thin-client model, a terminal for cloud service
- Protect different target
 - Disk write (think disk operation as a network traffic)
- Confidentiality protection
 - Gyrus only protects integrity of user intent.